



NEW!!

8.1L GM “EFI Base” Marine Engine

Quest Part # 051018N

The Quest 8.1L new “EFI Base” engine includes the following (when ordered under the above part number).

Block (with all internal engine components)
 Water Circulating Pump
 14” Flywheel
 GM Installed EFI (coil near plug ignition)

Harmonic Balancer
 Timing Chain Cover
 Oil Pan
 EFI Intake

Valve Covers
 Spark Plugs
 Plug Wires
 High Gloss Paint (non-corrosive)



8.1L Bobtail Pictured (part #041004)

Note: Some parts Shown in this above picture are NOT part of the “Base” build up (bobtail pictured).

Available Options:

-Hi Output Version Order Part # 051017N

Please Call about our full line of Transmissions!

Specifications

Displacement:	496 C.I.D. (8128 CC) / 8.1L
Cylinders:	90 Degree V8 Cylinder
Comp. Ratio:	9.1:1
Valve Config.:	Overhead Valves (2 valves per cylinder)
Valve Lifters:	Hydraulic Roller
Bore x Stroke:	4.25” x 4.37” (107.95 x 111 mm)
Main Bearings Caps:	Cast Nodular Iron
Ignition:	GM Installed “Coil Near Plug”
Intake Manifold:	EFI Intake / GM Installed
Block MFG.:	GM Powertrain
Flywheel Dia.:	14” (Ring Gear Towards Engine)
Firing Order:	1 - 8 - 7 - 2 - 6 - 5 - 4 - 3
Oil Pan Capacity:	10 Quarts
Oil Type:	SAE 15W40 Pennzoil Marine
Paint Protectant:	High Gloss Black / Superior Corrosion Resistant
Horsepower:	419 H.P. @ 5000 RPM
Torque:	503 lb-ft @ 4000 RPM
Warranty:	1 Year Limited (90 Days Commercial)

Note: Actual power levels may vary depending on Quest’s calibration and application.

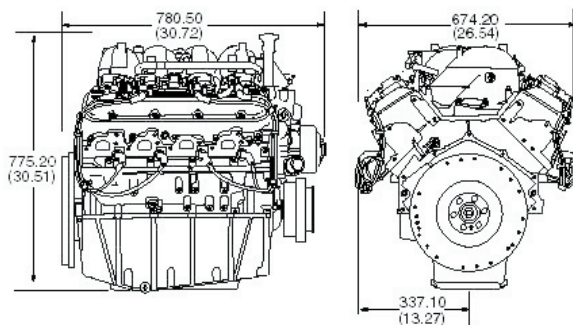

Toll Free: 1-866-255-9265
 www.barrmarine.net