



NEW!!

6.0L GM “Green” Base Marine Engine

Quest Part # 051022G

The Quest 6.0L new “Green” base engine includes the following (when ordered under the above part number).

Block (with all internal engine components)
 Water Circulating Pump
 Stock Flywheel
 Ignition System (coil near plug)
 Dip Stick Tube

Crank Pulley
 Circ. Pump Pulley
 Fuel System (GM supplied only)
 Water Circlating Pump
 Electronic Throttle Body

Valve Covers
 Spark Plugs
 Oil Pan
 Dip Stick



Specifications

Displacement:	364 C.I.D. (5967 CC) / 6.0L
Type:	6000 V-8
Comp. Ratio:	10.1:1
Valve Config.:	Overhead Valves (2 valves per cylinder)
Valve Lifters:	Hydraulic Roller
Bore x Stroke:	101.60 x 92 mm
Main Bearings Caps	Powder Metal
Fuel System:	Port Fuel Injection
Fuel Type:	Regular Unleaded
Fuel Shutoff:	5900 to 6000 RPM
Emmision Controls.:	Positive Crankcase Vent./Returnless Fuel System
Firing Order:	1 - 8 - 7 - 2 - 6 - 5 - 4 - 3
Horsepower:	380 H.P. @ 5200 RPM
Torque:	409 lb-ft @ 4200 RPM
Warranty:	1 Year Limited (90 Days Commercial)

Note: Actual power levels may vary depending on Quest’s calibration and application.

The new Vortec 6000 Marine Engine is sold through Quest exactly the way GM builds the engine for us.

The 6.0L “Green” base engine features an electronic throttle body, coil near plug ignition, a cylinder head inspired by the LS6 Corvette engine and many more features that will make this the perfect direct replacement for any boater!

(Note: The LQ-9/6.0L uses a MEFI 5 ECM)

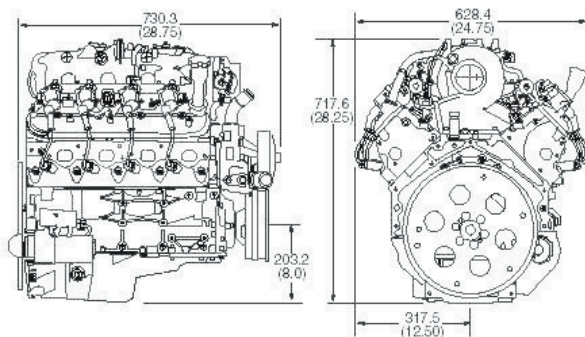

Toll Free: 1-866-255-9265
www.barrmarine.net